

AWP 508

“High strength stainless steel wire”

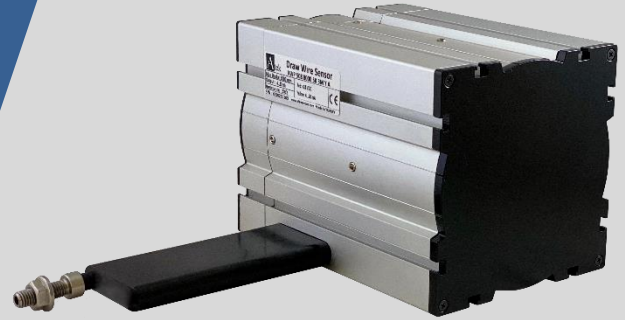

- Different stroke (measuring) lengths between 0...4000 mm and 0...8000 mm
- $\pm 0.5\%$ FS linearity
- Potentiometric, 0-10 VDC, 4-20 mA or CANopen output options
- IP54 protection class (Optional IP67)
- Compact design and easy installation
- Shock/vibration resistant
- Aluminum body

AWP 508 series draw wire sensors; consists of a rotary potentiometer which is controlled by stainless steel wire. They make measurement by pulling and rewinding stainless steel wire. They convert linear motion to potentiometric, analog or CANopen output.

MECHANICAL DATA

Mechanical and Environmental Data

Stroke (measuring) Length	Different measuring lengths between 0...4000 mm and 0...8000 mm	
Linearity	±0.5% FS	
Maximum Speed	0.5 m/s	
Required Force	10N	
Protection Class	IP54 (Optional IP67)	
Operating Temp.	-25°C ... +85°C	
Relative Humidity	%95	
Materials	Body	Aluminum/plastic
	Measuring Wire	Stainless steel

MECHANICAL DIMENSIONS (mm)

M12 Connector Output From Backside

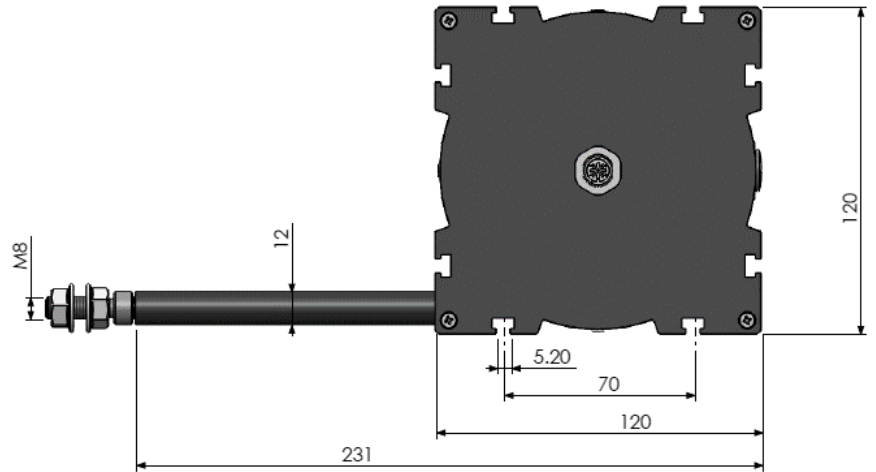
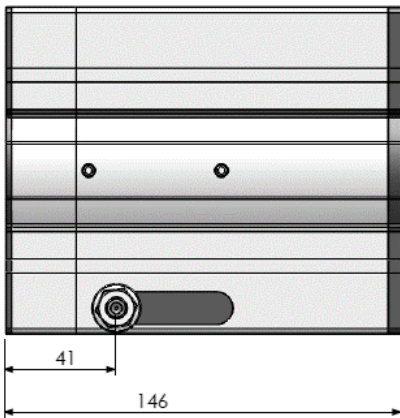

M12 Connector Output From Side

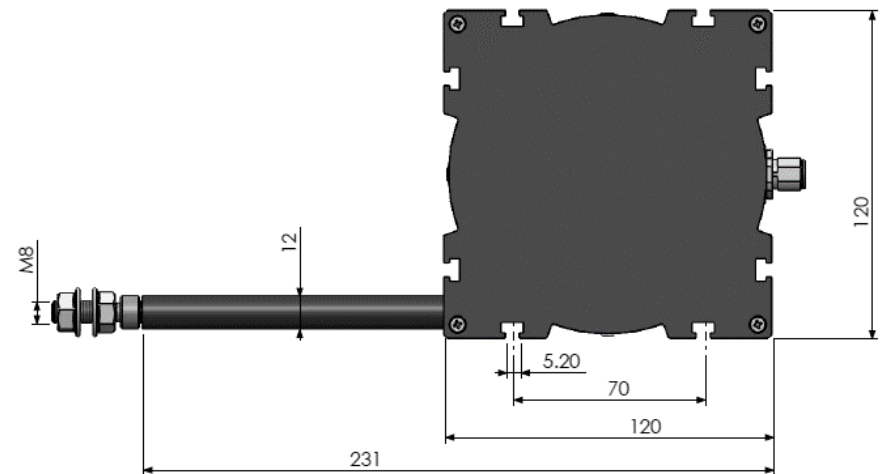
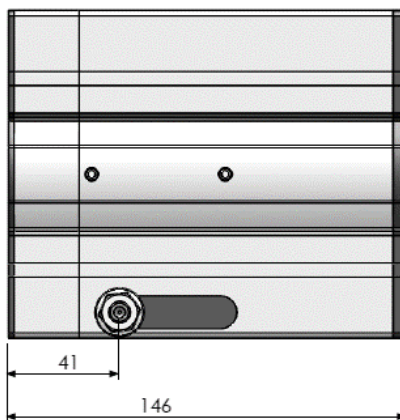

Cable Output From Backside

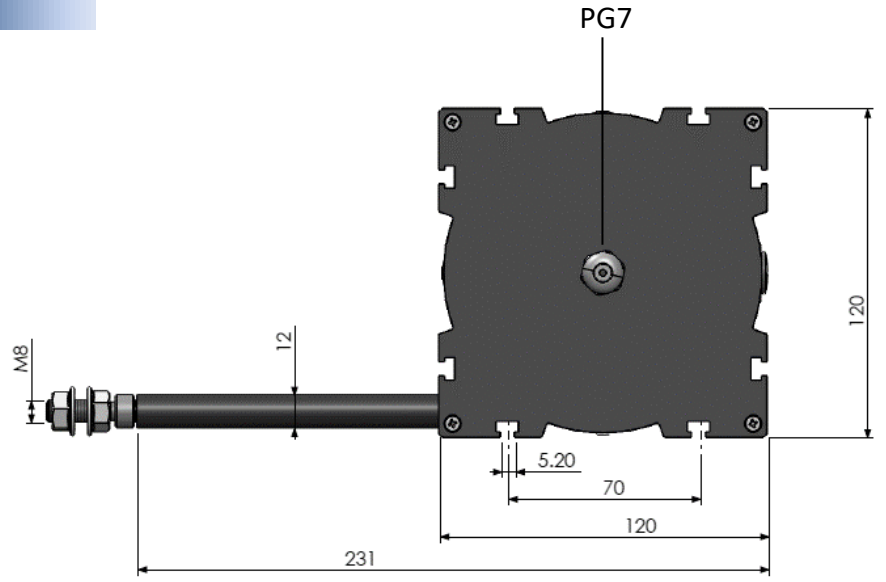
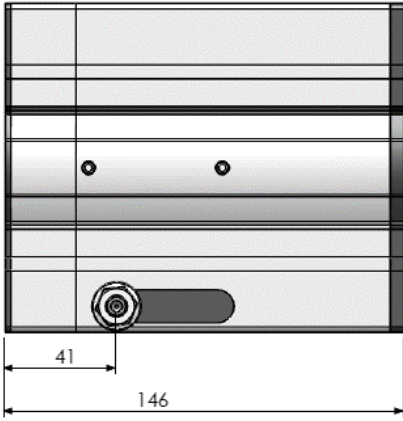

Cable Output From Side

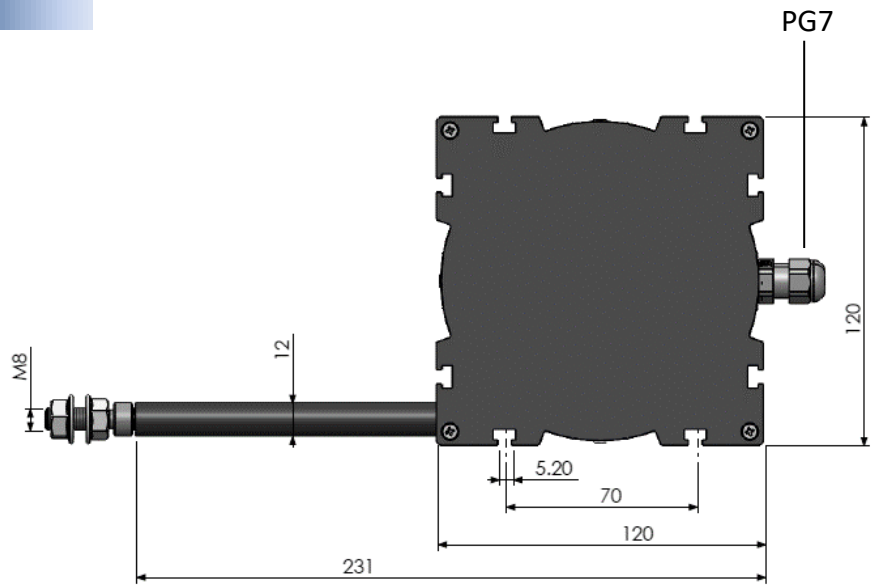
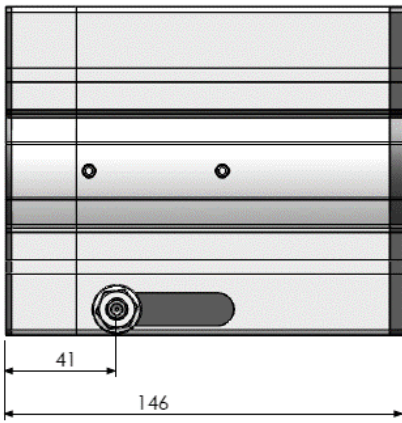

ANALOG OUTPUT

Measuring Type	Potentiometric		
Output Signals	Potentiometric	0 ... 10 V	4 ... 20 mA
Resistance	5 K Ω (standard), 10 K Ω	-	-
Supply Voltage	42V max.	12...30 VDC	12...30 VDC
Reverse polarity protection	Yes		
Short circuit protection	Yes		
Electrical Connection	3x0,14 mm ² shielded cable or M12 connector (optional others)		

0-10V or POTENTIOMETER Connection		
Signal	Cable Color	M12 5 pin male connector
Earth	Silver	Pin 1
+V	Red	Pin 2
0V	Black	Pin 3
0-10V / Pot	Yellow	Pin 4
-	-	Pin 5

4-20 mA Connection		
Signal	Cable Color	M12 5 pin male connector
Earth	Silver	Pin 1
+V	Red	Pin 2
-	-	Pin 3
4-20 mA	Yellow	Pin 4
-	-	Pin 5

- * 1 pcs M12 5 pin male connector is used as standard for single output models
- * Different socket models can be requested optionally.

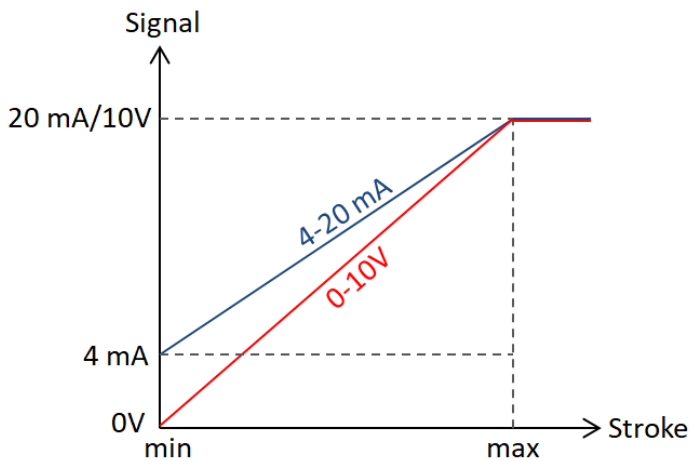

CANopen OUTPUT

Measuring Type	Potentiometric
Device Type	CANopen, CiA DS406
Communication profile	CiA 301
Node ID	Between 1 and 127, it can be adjusted with LSS or SDO
Baud Rate	10 kBit/s, 20 kBit/s, 50 kBit/s, 100 kBit/s, 125 kBit/s, 250 kBit/s, 500 kBit/s, 800 kBit/s, 1
PDO Data Rate	500 ms
Error Control	Heartbeat, Emergency Message
PDO	2 Tx PDO
PDO Modes	Event/Time triggered, Synch/Asynch
SDO	1 server
Position Information	Object Dictionary 6004
Termination Resistance	Optional, specify at the order stage.
Supply Voltage	10...30 VDC
Reverse polarity protection	Yes
Short circuit protection	Yes
Electrical Connection	6x0,34 mm ² twisted shielded cable or M12 5 pin male + M12 5 pin female connector

*Click for CANopen EDS file.

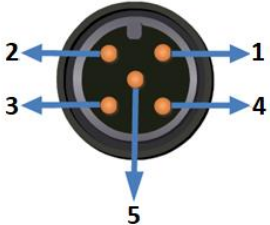
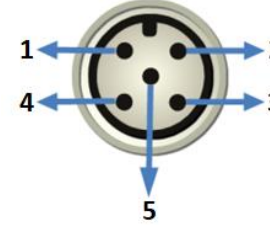
Signal	Cable Color	M12 5 pin male connector	M12 5 pin female connector
			
CAN_SHIELD	Silver (mesh)		Pin 1
+V (10...30 VDC)	Red		Pin 2
GND (0V)	Black		Pin 3
CAN_H	Yellow		Pin 4
CAN_L	Green		Pin 5

* CANopen models have 2 outputs. 1 pcs M12 5 pin male and 1 pcs M12 5 pin female sockets are used as standard.

* Different socket models can be requested optionally.

MOUNTING AND WARNINGS

1. Never release the wire after pulling. Otherwise, the coil spring will be damaged.

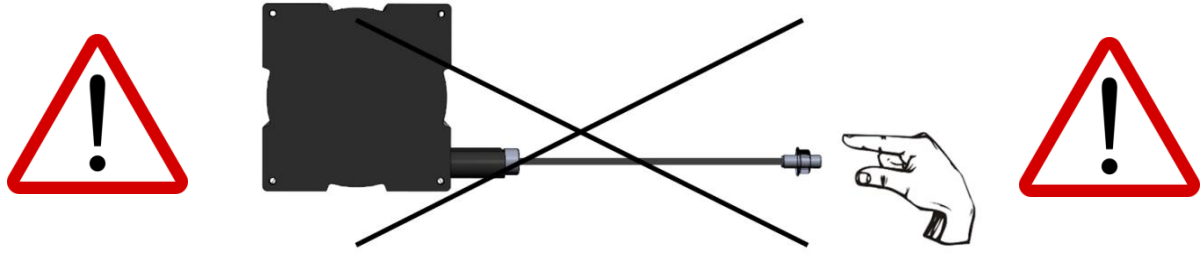

2. Mount the sensor according to the mounting directions shown below.

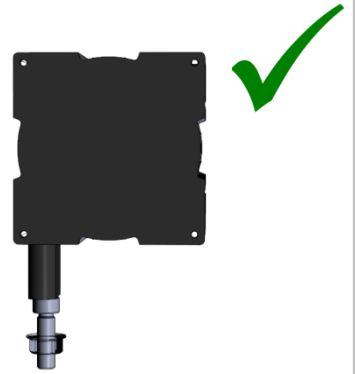
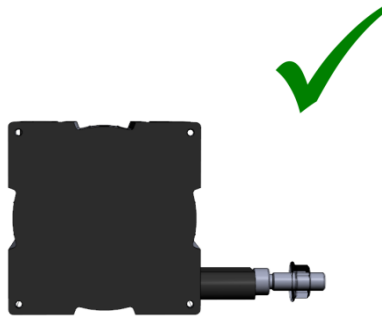
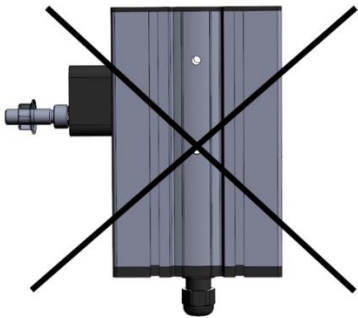

3. If there is a trickle of water (like a rain), the wire outlet must not be a drip of water upstream. If needed please use guide rollers.

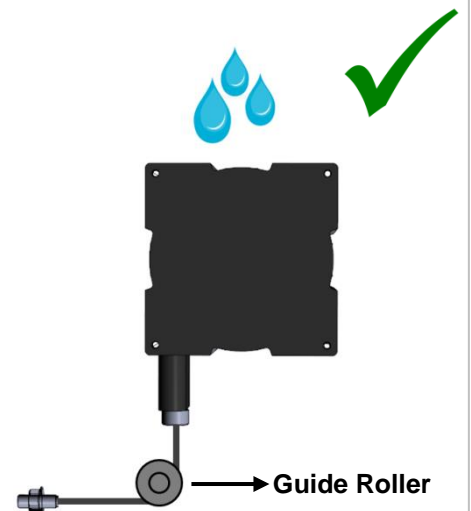
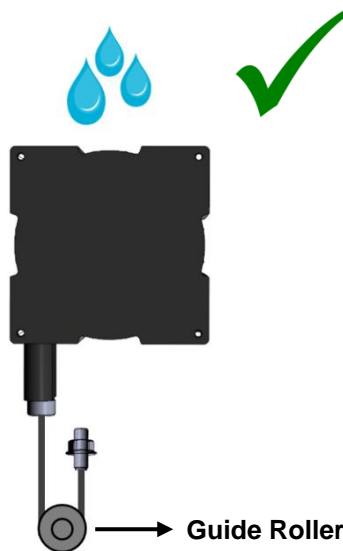

4. The wire should not be pulled in angular. If needed, please use guide rollers.

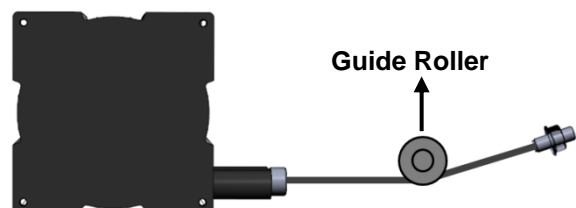
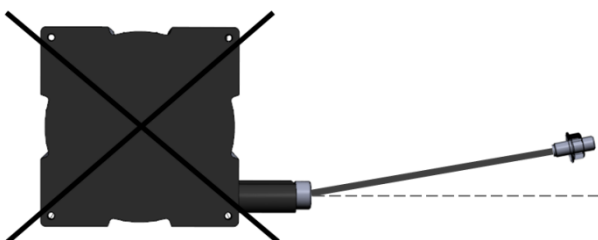

Important Note(!): Failure to comply with these recommendations, the malfunctions that may occur will not be under the warranty.

SAMPLE APPLICATION FIELDS

- Elevators
- Press machines
- Crane systems
- Wood processing machines
- Marble processing machines
- Storage positioning
- Dam protections
- Sluice gate control
- Air compressors
- Glass processing machines
- Lifting platforms
- Applications in medical technologies (operating table etc.)
- Forklifts
- Screw machines
- Paper machines
- Sewing machines
- Hydraulic machines
- Sheet metal machines
- Printing machines
- Horizontal control equipments
- Construction machines
- Industrial robots
- Injection machines
- X-Y axis displacement
- Liquid level measurements and position control

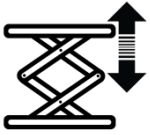

ORDER CODE

Model	-	XXXX	-	XXX	-	XXX	-	X	-	X	-	XXXX
<div style="display: flex; justify-content: space-between;"> <div style="width: 25%;"> <p>Resistance ⁽¹⁾</p> <p>No Code: Analog or CANopen output</p> <p>5K: 5 KΩ (standard)</p> <p>10K: 10 KΩ</p> </div> <div style="width: 25%;"> <p>Cable or Socket Direction</p> <p>B : From backside</p> <p>S : From side</p> </div> <div style="width: 25%;"> <p>Protection Class</p> <p>No code : IP54 (std)</p> <p>E067 : IP67</p> </div> </div>												
<p>Stroke Length</p> <p>Different measuring lengths between 0...4000 mm and 0...8000 mm</p>				<p>Electrical Connection⁽²⁾</p> <p>3M : 3 m cable</p> <p>5M : 5 m cable</p> <p>10M : 10 m cable</p> <p>S13F : M12 5 pin female conn.</p> <p>S13M : M12 5 pin male conn.</p> <p>S13FM: M12 5 pin female + M12 5 pin male Conn.(available on CANopen models)</p>				<p>Output Signals</p> <p>No Code : Potentiometric</p> <p>V : 0-10 VDC</p> <p>A : 4-20 mA</p> <p>C : CANopen</p>				

(1) For products with analog or CANopen output, resistance value is not selected. Please contact for other resistance options for potentiometric output products.

(2) The product can be requested with cable or socket.

As standard;

For analog output models, 1 pcs M12 5 pin male socket (S13M) is used.

For CANopen output models, 1 pcs M12 5 pin female + 1 pcs M12 5 pin male socket (S13FM) is used.

However, different socket combinations may be requested as in the examples below.

Please contact us for any other socket model other than M12.

Sample 1 (Potentiometric output): AWP 508-5000-5K-S13M-S

AWP 508 series, 5000 mm stroke, 5K resistance, **M12 5 pin male socket**, side socket outlet, potentiometric output

Sample 2 (CANopen output): AWP 508-5000-S13FM-B

AWP 508 series, 5000 mm stroke, **1 pcs M12 5 pin female + 1 pcs M12 5 pin male socket**, backside socket outlet, CAN output

Sample 3 (Analog output): AWP 508-5000-3M-S-A

AWP 508 series, 5000 mm stroke, **3 meters cable output**, side cable outlet, current output